

(No Model.)

2 Sheets—Sheet 1.

S. D. ALLISON. AXLE CUTTER.

No. 540,621.

Patented June 11, 1895.

Fig. 1.

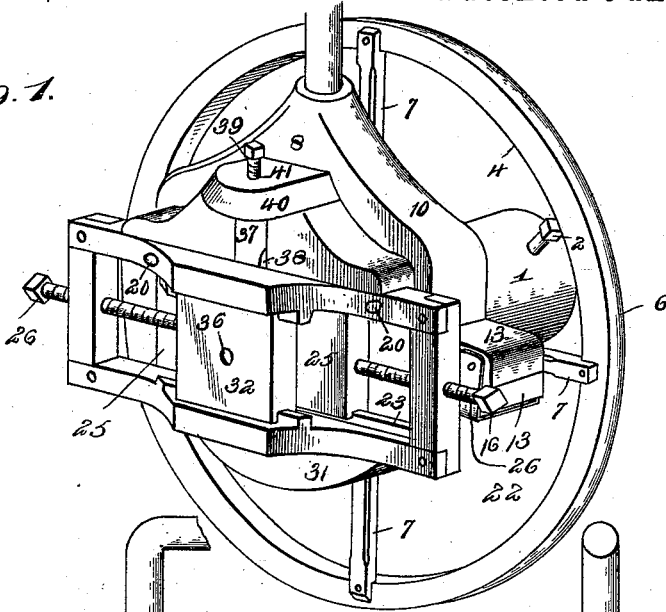

Fig. 2.

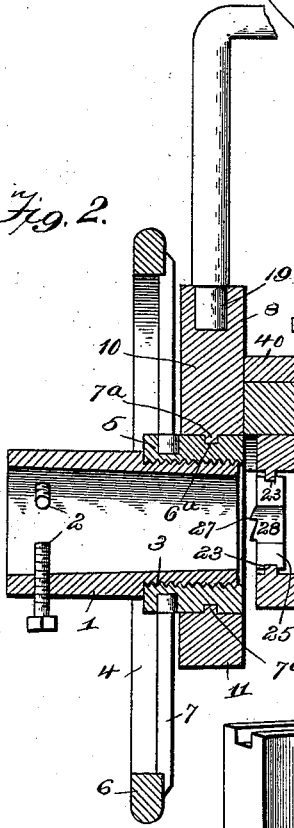

Fig. 3.

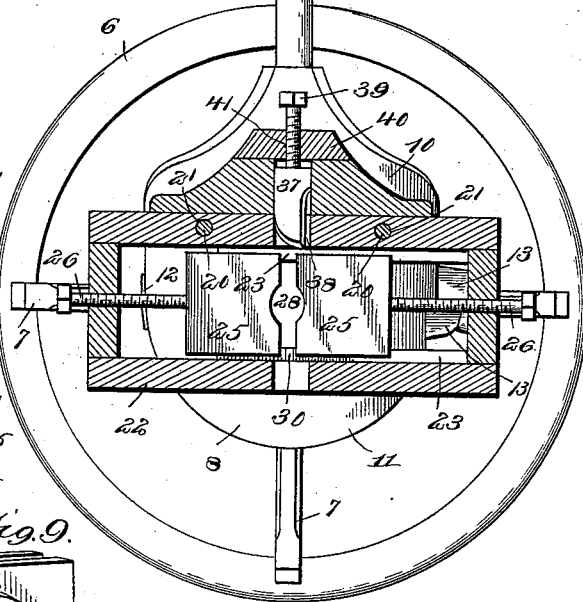

Fig. 9.

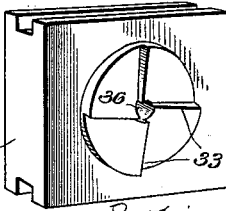
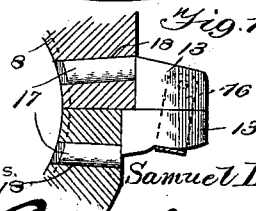

Fig. 10.



Witnesses

John C. Shaw.
J. W. Riley

By *his* Attorneys,

Inventor

Samuel D. Allison,

Chas. H. Snow & Co.

(No Model.)

2 Sheets—Sheet 2.

S. D. ALLISON.
AXLE CUTTER.

No. 540,621.

Patented June 11, 1895.

Fig. 4.

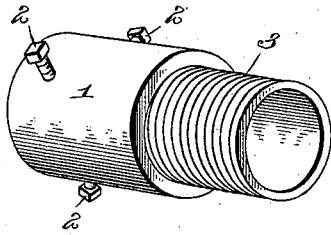

Fig. 5.

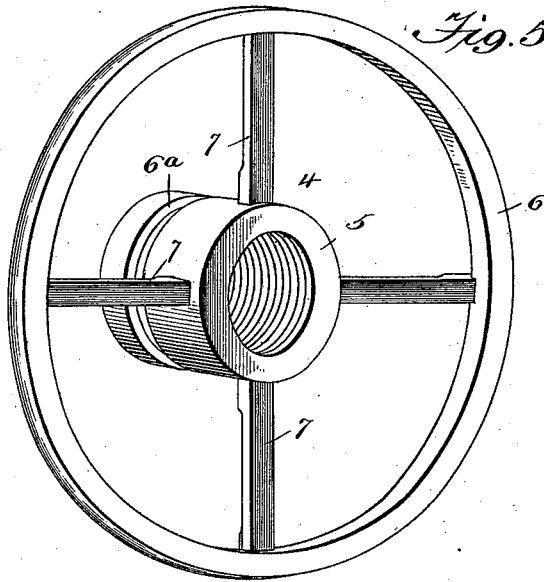

Fig. 6.

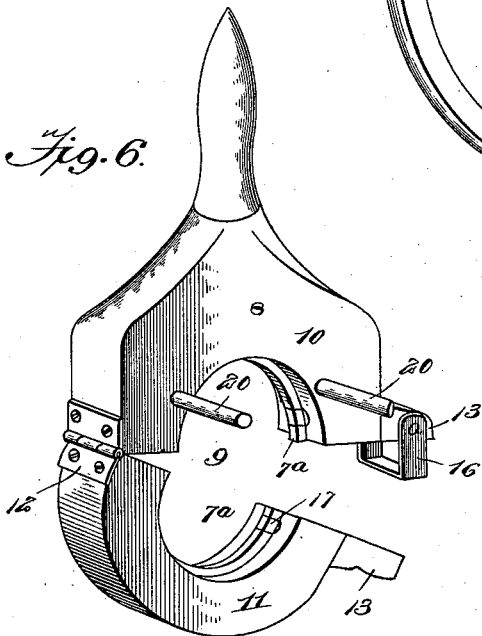

Fig. 7.

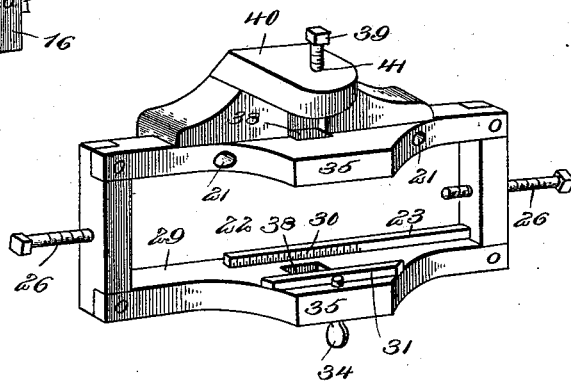
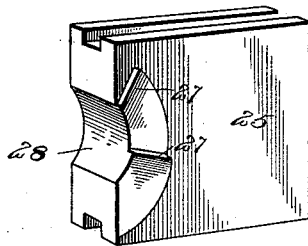

Fig. 8.



Witnesses

John C. Shaw
J. H. Riley

By his Attorneys.

Inventor
Samuel D. Allison,

C. Snow & Co.

UNITED STATES PATENT OFFICE.

SAMUEL D. ALLISON, OF THOMASVILLE, GEORGIA.

AXLE-CUTTER.

SPECIFICATION forming part of Letters Patent No. 540,621, dated June 11, 1895.

Application filed October 12, 1894. Serial No. 525,709. (No model.)

To all whom it may concern:

Be it known that I, SAMUEL D. ALLISON, a citizen of the United States, residing at Thomasville, in the county of Thomas and State of Georgia, have invented a new and useful Axle-Cutter, of which the following is a specification.

The invention relates to improvements in axle cutters.

The object of the present invention is to improve the construction of axle cutters, and to provide a simple and inexpensive one capable of readily cutting down the shoulder of a spindle, shortening the end thereof, and of threading the latter, whereby, after an axle or box has become worn, the axle may be made to fit the box properly without employing additional washers to compensate for the wear.

The invention consists in the construction and novel combination and arrangement of parts hereinafter fully described, illustrated in the accompanying drawings, and pointed out in the claims hereto appended.

In the drawings, Figure 1 is a perspective view of an axle-cutter constructed in accordance with this invention. Fig. 2 is a longitudinal sectional view of the same. Fig. 3 is a transverse sectional view. Fig. 4 is a detail perspective view of the stationary sleeve or cuff. Fig. 5 is a similar view of the feed-wheel. Fig. 6 is a detail perspective view of the rotary body portion, the sections being swung apart. Fig. 7 is a detail perspective view of the cutter-holding frame, the cutters being removed. Fig. 8 is a detail perspective view of one of the laterally-adjustable cutting-dies. Fig. 9 is a similar view of the end die. Fig. 10 is a detail sectional view of a portion of the rotary body.

Like numerals of reference indicate like parts in all the figures of the drawings.

1 designates a sleeve or cuff, designed to be placed on an axle, and provided with radial clamping-screws 2 for permanently securing it to the axle, and having an outer reduced threaded portion 3, receiving a feed-wheel 4, adapted to be operated by hand to regulate the cutting devices hereinafter described.

The feed-wheel 4 consists of an interiorly-threaded hub 5, an outer rim 6, and connecting-spokes 7; and the hub is extended outward and is provided with an annular groove

6^a, which is engaged by curved interiorly-arranged ribs or flanges 7^a, of a rotary body portion 8, which carries the cutters and which is detachably swiveled to the feed-wheel. The rotary body 8 is provided with a central circular opening 9, on the interior of which are located the said ribs; and the body is composed of two sections 10 and 11, connected at one side by a hinge 12, and provided at the opposite side with projecting lugs 13, connected detachably by a swinging bail or frame 16, and provided with shanks 17, fitted in corresponding sockets 18, of the sections. The section 10 of the rotary body is provided with a socket 19, for the reception of a handle for rotating the axle cutter, and it is provided, on its front or outer face with projecting pins 20, fitting in corresponding sockets or openings 21, of a cutter-holding frame 22, whereby the latter is attached to the rotary body.

The cutter-holding frame is substantially rectangular or oblong, and it is provided, on the inner faces of its sides with longitudinal ribs 23, forming guides for laterally-adjustable dies 25, which are moved inward by adjusting-screws 26, mounted in threaded perforations of the ends of the frame. The cutting dies 25 are provided on their inner faces with cutting edges 27, for reducing the shoulder of a spindle; and it will be readily apparent that instead of employing the cutting dies 25, similar ones for cutting screw-threads may be readily employed. At their side edges the cutting dies are provided with grooves 28, and the ribs, which form the guides for the dies, terminate short of one end of the frame to provide an open space 29, to permit the dies to be readily arranged on the guides or ways and removed therefrom. One of the ribs which form the guides is provided with graduations 30, to indicate the degree of cutting, and to enable axles to be readily trimmed.

The sides of the rectangular cutter-holding frame have central outward extensions or enlargements, and are provided with centrally-arranged ribs 31, forming guides or ways for a grooved cutting die 32, for engaging the end of a spindle to shorten the same; and this die is provided at its inner face with centrally-arranged cutting edges 33, and is secured in proper position by a set-screw 34, mounted on one of the enlargements 35. The cutting

edges 33 extend substantially radially from a central perforation or opening 36 of the die 32. The laterally-adjustable dies and the centrally-arranged end die operate simultaneously, the centrally-arranged die 32 cutting off the end of the axle, while the laterally-adjustable dies are cutting down the shoulder. A lathe bit or cutter 37 is mounted in a socket or opening 38 of the frame 22, for cutting off or reducing the shoulder of an axle, and it is adjusted by means of a screw 39, mounted in a threaded perforation of the flange 40 of a stock 41, which is secured to one side of the cutter-holding frame.

15 It will be seen that the axle cutter is simple and comparatively inexpensive in construction, and that it is capable of convenient operation, and is adapted to reduce quickly the end of an axle and the shoulder thereof to take up the wear.

20 Changes in the form, proportion, and the minor details of construction may be resorted to without departing from the principle or sacrificing any of the advantages of this invention.

25 What I claim is—

1. In an axle cutter, the combination of a sleeve or cuff having a threaded portion, an interiorly-threaded feed-wheel arranged on the sleeve or cuff and having its hub extended and provided with an annular groove, and a rotary body carrying dies and having a circular opening, and composed of two sections

hinged together at one side of the body and detachably connected at the opposite side, said sections being provided with interior curved ribs engaging the annular groove of the feed-wheel, substantially as described.

2. In an axle cutter, the combination of a rotary body, a cutter-carrying frame mounted on the body, the oppositely-disposed adjustable cutters or dies mounted in the frame, and the removable centrally-arranged die mounted in the frame and located beyond and opposite the inner ends of the side cutters, and provided on its inner face with cutting edges for engaging the end of an axle, substantially as described.

3. In an axle cutter, the combination of a rotary body, a rectangular frame mounted thereon and provided on its interior with longitudinally-disposed ribs forming ways and terminating short of one end of the frame, grooved dies adjustably mounted on the ribs, the centrally-arranged ribs mounted on said frame, and the central cutting die having grooves to fit the central ribs and provided on its inner face with cutting edges, substantially as described.

In testimony that I claim the foregoing as my own I have hereto affixed my signature in the presence of two witnesses.

SAMUEL D. ALLISON.

Witnesses:

ACHILLES SMITH,
D. J. SHEFFIELD.